

THE EFFECT OF NOZZLE EROSION ON HEAT TRANSFER IN A LADLE OF MOLTEN STEEL DURING POURING

P. EGERTON, J. A. HOWARTH and G. POOTS

Department of Applied Mathematics, University of Hull, Hull HU6 7RX, U.K.

(Received 22 January 1980 and in revised form 21 August 1980)

Abstract — The fire clay nozzle, inserted in the brick insulation at the base of a pouring ladle, is observed to erode as the molten steel pours from the ladle. A phenomenological theory of nozzle erosion is proposed. The effect of nozzle erosion on the nozzle streaming temperature is then investigated. The results are compared with the fixed orifice theoretical model [1] and with plant observations.

NOMENCLATURE

a ,	radius of ladle;
A_L ,	cross-sectional area of ladle;
A_N ,	cross-sectional area of nozzle;
B_i ,	Biot number;
C_N ,	nozzle contraction factor;
$D(t)$,	nozzle diameter;
f ,	nozzle friction factor;
g ,	gravitational acceleration;
$h(t)$,	head of steel at time t ;
H_0 ,	initial head of steel;
$H^*(\tau)$,	dimensionless head of steel at time τ ;
k ,	thermal diffusivity;
K ,	thermal conductivity;
$K_N(\tau), \Lambda_N(\tau)$,	modified contraction factors;
L ,	nozzle length;
p ,	pressure;
(r, z) ,	cylindrical polar co-ordinates;
(R, Z) ,	dimensionless cylindrical polar co-ordinates;
$R(t)$,	radius of nozzle;
R_0 ,	initial radius of nozzle;
$R^*(\tau)$,	dimensionless radius of nozzle at time τ ;
t ,	time;
T ,	temperature;
T_1 ,	initial temperature;
v ,	fluid velocity;
U, V ,	radial and axial dimensionless temperature functions;
W_N ,	nozzle wear factor.

Greek symbols

β ,	total fractional nozzle wear;
ε ,	$= kt_f/H_0^2$, dimensionless emptying time;
θ ,	$=(T - T_0)/(T_1 - T_0)$, normalized dimensionless temperature;
λ ,	dimensionless contraction factor;
ϕ_0, ϕ_1 ,	coefficients for velocity expansion at small time;
ρ ,	density;

$\tau = t/t_f$,	dimensionless time;
ω ,	dimensionless wear constant.

Subscripts

0,	ambient condition;
1,	wall condition;
2, T ,	slag conditions;
B ,	inner ladle base conditions;
F ,	fusion;
f ,	emptying time;
h ,	atmospheric condition;
L ,	ladle condition;
N ,	nozzle condition.

1. INTRODUCTION

THE STUDY of heat transfer in a ladle of molten steel is of considerable interest in the metallurgical industries. Little theoretical work appears to have been done on this problem. Szekely and Chen [2] have given an approximate treatment of heat transfer for the waiting period prior to pouring from the ladle (mainly with a view to suppressing free convection during this period). In a recent paper [1] a theoretical model was proposed for heat transfer in a ladle of molten steel during pouring. Certain developments have been made to the original model, which we describe here. In the interests of brevity, we will keep the exposition to a minimum, and refer heavily to [1].

The most common method of pouring is through an off-centre fire clay nozzle built into the brick insulation at the ladle base (see Fig. 1). On installation the nozzle has an internal diameter of 0.05 m. It is observed that during a pouring sequence of 1 h, with an initial ferrostatic head of 4 m, the internal diameter of the nozzle is eroded to 0.075 m, this rate of erosion being uniform along its length. This erosion has a significant effect on the pouring velocity, much greater, for example, than that of ladle taper, or that of the viscosity of molten steel.

It is the purpose of this note to develop a phenomenological theory of the erosion of the nozzle, based on

the above plant observations, and to investigate its effect on the flow of molten steel and the nozzle streaming temperature. Therefore, apart from consideration of nozzle erosion, the underlying assumptions are the same as those of the previous paper [1].

2. INVISCID LADLE FLOW WITH NOZZLE EROSION

The flow of the molten steel in the ladle is assumed to be inviscid and irrotational; the reasoning behind this is set out in detail in [1]. The ladle is represented by a circular cylinder having (mean) radius $a = (a_T + a_B)/2$ (see Fig. 1). In the same notation as [1], the top surface is located at $z = h(t)$, with $h(0) = H_0$. Bernoulli's equation yields (since $\dot{h}(t) \ll v_B$)

$$(p_B - p_h)/\rho = gh - \frac{1}{2}v_B^2 \tag{2.1}$$

where the suffices B and h denote conditions at the bottom and top surface, respectively.

Typically the nozzle Reynolds number is $O(10^6)$ and it is assumed that the nozzle flow is turbulent and fully developed. If v_N is the turbulent velocity of pouring then, on neglecting the small ferrostatic pressure drop along the nozzle length L [$h(t) > L$ for the major part of the teem], the pressure drop along the nozzle is given empirically by

$$(p_B - p_N)/\rho = [fL/2D(t)]v_N^2. \tag{2.2}$$

Here f is the (nozzle) friction factor and the suffix N denotes the condition at the nozzle outlet; $D(t)$ denotes the nozzle diameter. Note that in (2.1) and (2.2) $p_N = p_h$. Conservation of mass yields

$$-A_L \dot{h}(t) = C_N v_B A_N = v_N A_N \tag{2.3}$$

where A_L and A_N are the cross-sectional areas of the ladle and nozzle, respectively; C_N is the nozzle contraction factor. The eroded surface of the fire clay

nozzle will be considered rough and so for (complete) turbulence, at high Reynolds number, the friction factor will depend on relative roughness. In practice f is well represented by

$$f^{-1/2} = 2 \log_{10}(D/2e) + 1.74 \tag{2.4}$$

where e is a roughness height. Employing (2.1)–(2.3) it follows that, at any instant during the teem,

$$v_N = K_N [2gh(t)]^{1/2}, \quad K_N(t) = C_N \left(1 + f \frac{L}{D} C_N^2\right)^{-1/2} \tag{2.5}$$

At this stage in the development of the model the modified contraction factor $K_N(t)$ need not be specified.

We now come to the problematical question of the precise mechanism of the wearing effect of the liquid steel motion on the fire clay nozzle. We know of no studies bearing upon this in the literature. Furthermore, detailed experimental knowledge of the process is very difficult to obtain. Even precise information on the height of the head of steel in the ladle as a function of time, and the radius of the nozzle as a function of time is not available. What we do know is the initial head of steel, the final emptying time, and the initial and final radius of the nozzle. Our model must work within these constraints. As a first attempt, one might simply assume that the nozzle wears away as, say, a linear, or perhaps quadratic function of time, and fit this assumed law to the data available. However, this has a disagreeably *ad hoc* character about it, and it would be preferable to attempt to explain the erosion in terms of a law of wearing. In the absence of anything better, the following law is postulated, and is not unreasonable physically. We assume that the rate at which the material wears away is proportional to the rate at which the fluid does work on the internal

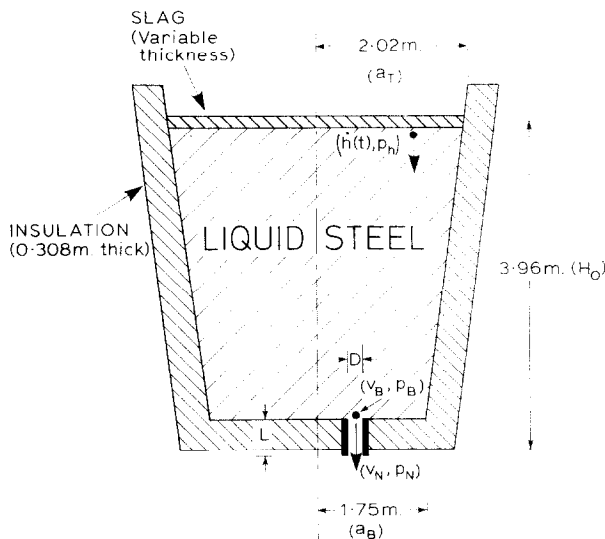

FIG. 1. Teeming ladle. $L = 0.3$ m and $0.05 \leq D(t) \leq 0.075$ m for $0 \leq t \leq t_f$, $t_f = 1$ h.

surface of the nozzle. In the nozzle the flow will be turbulent, and so we may write this as

$$dA_N/dt \propto Fv_N \quad (2.6)$$

where $F/2\pi R$ is the turbulent wall shear stress given by $\rho f v_N^2/8$. Employing (2.4), the erosion law (2.6) can be written in terms of the nozzle radius $R(t)$ and ferrosstatic head $h(t)$ as follows:

$$dR/dt = W_N h(t)^{3/2} \quad (2.7)$$

for some factor W_N . In fact W_N will be a function of t since it depends on $K_N^3(t)$ and the wear (proportionality) factor of (2.6) which, in general, must also depend on t .

Returning now to the equation of conservation of mass it follows

$$dh/dt = -\pi R^2 v_N/A_L = -2\Lambda_N R^2 h^{1/2} \quad (2.8)$$

where the factor Λ_N is proportional to $K_N(t)$.

The phenomenological theory of nozzle erosion now contains two unknown factors $W_N(t)$ and $\Lambda_N(t)$ which are essentially the erosion and contraction factors (respectively) during the teeming time $0 \leq t \leq t_f$. It is now assumed that the variations with t of W_N and Λ_N , during the teem, are small compared with the variation in either $h(t)$ or $R(t)$. From here on W_N and Λ_N are taken to be constant and will be called the wear constant and contraction factor of the process. They are now determined from plant data on the total extent of erosion (during emptying) and on the observed emptying time t_f of the ladle.

It is convenient to introduce the dimensionless variables

$$R = R_0 R^*, \quad h = H_0 H^*, \quad \tau = t/t_f \quad (2.9)$$

where R_0 and H_0 denote the nozzle radius and ferrosstatic head, respectively, at time $t = 0$. Writing $\omega = W_N H_0^{3/2} t_f/R_0$ and $\lambda = R_0^2 t_f \Lambda_N/H_0^{1/2}$ the governing equations (2.7) and (2.8) become

$$dR^*/d\tau = \omega H^{*3/2}, \quad dH^*/d\tau = -2\lambda R^{*2} H^{*1/2} \quad (2.10)$$

subject to the boundary conditions

$$R^*(0) = H^*(0) = 1, \quad H^*(1) = 0, \quad R^*(1) = (1 + \beta). \quad (2.11)$$

Here $(1 + \beta)$ is the factor by which the nozzle radius has finally worn. Measurement of plant specimens yields a typical value of $\beta = \frac{1}{2}$.

Equations (2.10) and (2.11) constitute a second order (nonlinear) boundary value problem with four boundary conditions. This is sufficient to determine the dimensionless wear constant ω and the contraction factor λ . Whilst these equations must be integrated numerically it is possible to find ω and λ explicitly. From (2.10) it follows on division and integration that

$$\int_1^{R^*} R^{*2} dR^* = (\omega/2\lambda) \int_H^1 H^* dH^* \quad (2.12)$$

yielding

$$R^{*3} = 1 + (3\omega/4\lambda)(1 - H^{*2}). \quad (2.13)$$

In particular when $H^* = 0$, $R^* = (1 + \beta)$ so that

$$(3\omega/4\lambda) = (1 + \beta)^3 - 1 \quad (2.14)$$

and hence (2.13) becomes

$$R^{*3} = 1 + \{(1 + \beta)^3 - 1\}(1 - H^{*2}). \quad (2.15)$$

Eliminating R^* from (2.10) yields

$$\int_0^1 H^{*-1/2} [1 + \{(1 + \beta)^3 - 1\}(1 - H^{*2})]^{-2/3} dH^* \\ = 2\lambda \int_0^1 d\tau \quad (2.16)$$

and hence

$$\lambda = \int_0^1 [1 + \{(1 + \beta)^3 - 1\}(1 - u^2)]^{-2/3} du \quad (2.17)$$

where $u = H^{*2}$. λ can be expressed as an incomplete beta function but it is more expedient, given β , to determine λ numerically and hence (2.14) determines the dimensionless wear constant ω . Once λ and ω are known we may now integrate (2.10) numerically as an initial value problem with $R^*(0) = H^*(0) = 1$. For $\beta = \frac{1}{2}$ we find $\lambda = 0.512$ and $\omega = 1.622$.

In Fig. 2, $H^*(\tau)$ and $R^*(\tau)$ are given for the (rough pipe) erosion model; $H^*(\tau) = -2(1 - \tau)$, for the model ignoring erosion [1], is included for comparison. The erosion model predicts that the nozzle flux of molten steel has a maximum about half way through teem and that at this stage the nozzle erosion is nearly finished. This prediction of nearly uniform nozzle flux for the major portion of the teem agrees well with plant observations. Also displayed are the results obtained by assuming the R^* varies linearly or quadratically with time (see Appendix for details). It will be seen that both these and the above model give the same general trends.

Finally it should be noted that other modifications of the above model have been investigated, such as the inclusion of ladle taper and the use of smooth pipe data for f ($f = 0.184 Re_D^{-1/3}$, $10^4 < Re_D < 10^5$). None of these significantly alters the results already displayed in Fig. 2.

3. CALCULATION OF THE NOZZLE STREAMING TEMPERATURE

The theory of Section 3 of [1] may in fact be generalized for any $H^*(\tau)$; the original theory was of course for $H^*(\tau) = (1 - \tau)^2$. Following [1] we consider the representative case of an insulating slag interface ($Bi_2 = 0$). In terms of the dimensionless variables (2.10) of [1], namely

$$Z = z/H_0, \quad R = r/a, \quad \tau = t/t_f, \quad (3.1)$$

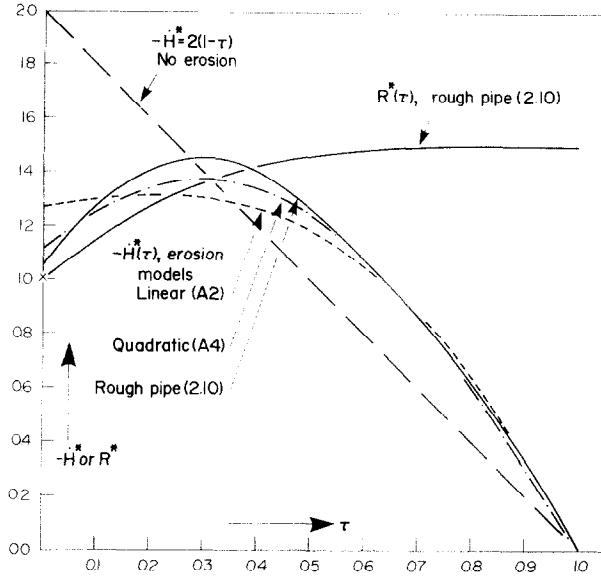

FIG. 2. Dimensionless vertical velocity $-\dot{H}^*(\tau)$ of slag interface and dimensionless nozzle radius $R^*(\tau)$. $\tau = t/t_f$.

$$\theta = (T - T_0)/(T_1 - T_0) \quad \text{and} \quad \varepsilon = kt_f/H_0^2$$

the dimensionless molten steel temperature can again be separated into radial and axial components as follows

$$\theta(R, Z, \tau; \varepsilon) = U(R, \tau; \varepsilon) V(Z, \tau; \varepsilon). \quad (3.2)$$

In the present erosion model V satisfies the equations:

$$\frac{\partial V}{\partial \tau} + \dot{H}^*(\tau) \frac{\partial V}{\partial Z} = \varepsilon \frac{\partial^2 V}{\partial Z^2}, \quad (3.3)$$

$$\frac{\partial V}{\partial Z} = Bi_1 V \quad \text{at} \quad Z = 0, \quad \tau > 0, \quad (3.4)$$

$$\frac{\partial V}{\partial Z} = 0 \quad \text{at} \quad Z = H^*(\tau), \quad \tau > 0, \quad (3.5)$$

and

$$V = 1, \quad \tau = 0, \quad 0 \leq Z \leq 1. \quad (3.6)$$

From (typical) plant data $\varepsilon = 1.6 \times 10^{-3}$ and the ladle base Biot number $Bi_1 = (H_0 h_1 / K) = 2.5$.

Suppose that for small τ

$$\dot{H}(\tau) = \phi_0 + \phi_1 \tau + O(\tau^2). \quad (3.7)$$

The whole of the singular perturbation theory of [1] goes through and, in the notation of [1], we find the four region structure:

Region 1: $Z = Z, \quad \tau^* = \tau/\varepsilon, \quad V = V^*(Z, \tau^*),$
 $V^* = 1 + O(\varepsilon^2); \quad (3.8)$

Region 2: $\bar{Z} = Z/\varepsilon, \quad \tau^* = \tau/\varepsilon, \quad V = \bar{V}^*(\bar{Z}, \tau^*),$
 $\bar{V}^* = 1 + (\varepsilon Bi_1 / 2\phi_0) \left\{ (1 + \phi_0 \bar{Z} + \phi_0^2 \tau^{*2}) \right.$

$$\times \operatorname{erfc} \left(\frac{\bar{Z}}{2\tau^{*1/2}} + \frac{\phi_0}{2} \tau^{*1/2} \right) - \exp(-\phi_0 \bar{Z}) \operatorname{erfc} \left(\frac{\bar{Z}}{2\tau^{*1/2}} - \frac{\phi_0}{2} \tau^{*1/2} \right) - \left. \frac{2\phi_0}{\pi^{1/2}} \exp \left[- \left(\frac{\bar{Z}}{2\tau^{*1/2}} + \frac{\phi_0}{2} \tau^{*1/2} \right)^2 \right] \right\}. \quad (3.9)$$

Region 3: $Z = Z, \quad \tau = \tau, \quad V = V(Z, \tau),$
 $V = 1 + O(\varepsilon^2); \quad (3.10)$

Region 4: $\bar{Z} = z/\varepsilon, \quad \tau = \tau, \quad V = \bar{V}(\bar{Z}, \tau),$
 $\bar{V} = 1 + [\varepsilon Bi_1 / \dot{H}^*(\tau)] \exp\{-\dot{H}^*(\tau) \bar{Z}\}. \quad (3.11)$

The nozzle streaming temperature at $\bar{Z} = 0$ is readily evaluated from (3.9) and (3.11) and in particular for $\tau = O(1)$ we obtain

$$(T_N - T_0)/(T_1 - T_0) = 1 + \varepsilon Bi_1 / \dot{H}^*(\tau). \quad (3.12)$$

Note that in the above derivation, as well as the assumptions already made in [1], it has also been assumed that there has been no heat loss in the molten steel temperature along the (short) length of the fire clay nozzle.

In Fig. 3 the dimensionless nozzle streaming temperature θ_N is displayed together with the results of [1] for a fixed orifice model and plant observations showing variations between two separate casts; note that $\theta_F = (T_F - T_0)/(T_1 - T_0)$, where T_F is the molten steel fusion temperature.

The new feature revealed on including the effect of nozzle erosion is the shallow dip in the nozzle temperature followed by a rise to a (plateau) temperature value which is then maintained for most of the teem. This feature is of course attributable to the "flattening" of

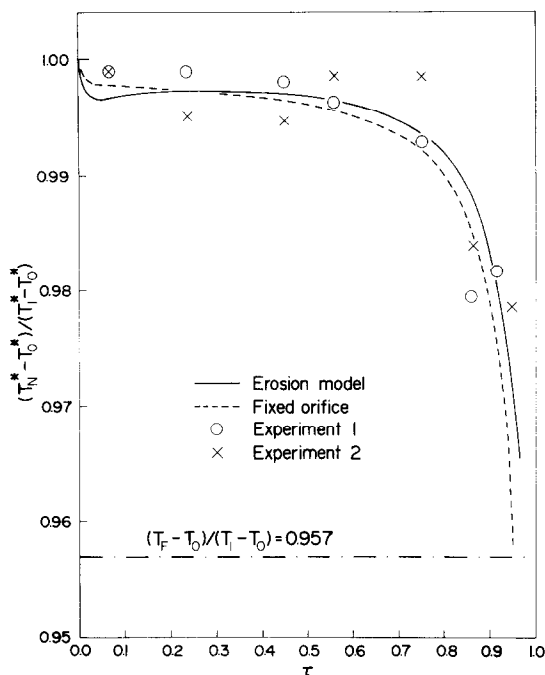

FIG. 3. Theoretical and experimental values of dimensionless nozzle streaming temperature against time ($Bi_1 = h_1 H_0 / K = 2.5$, $\varepsilon = kt_f / H_0^2 = 1.6 \times 10^{-3}$).

the nozzle velocity profile by the erosion mechanism. The erosion model theory also predicts a higher nozzle streaming temperature for the major part of the teem.

Various other thermal conditions have been investigated on direct numerical integration of (3.3) by means of the Crank–Nicolson method, see [1]. In this way allowance can be made for an initial standing period prior to pouring, the thermal capacity of the walls, ladle taper and radiation at the slag interface. The general trend of the numerical results are more or

less identical to those displayed in Fig. 3 (and in [1]) and so details will not be given.

4. CONCLUSIONS

A phenomenological theory of nozzle erosion has been developed. This is then used to yield theoretical predictions on ladle flow and heat transfer during teeming. The results are in good agreement with plant observations.

Acknowledgement — One of us (P.E.) is indebted to the Science Research Council for a maintenance grant. We are indebted to Mr. V. J. Small and Mr. R. R. Rae (British Steel Corporation (Scunthorpe)) for suggesting this work and for their continued interest in the problem.

REFERENCES

1. P. Egerton, J. A. Howarth, G. Poots and S. Taylor-Reed, A theoretical investigation of heat transfer in a ladle of molten steel during pouring, *Int. J. Heat Mass Transfer* **22**, 1525–1532 (1979).
2. J. Szekely and J. H. Chen, The role of natural convection in ladles as affecting tundish temperature control in continuous casting, *Metall. Trans.* **2**, 1189–1192 (1971).

APPENDIX

If we assume the simple linear law

$$R^* = 1 + \beta\tau \quad (\text{A1})$$

then it follows almost immediately from (2.8) and the boundary conditions that

$$H^* = \left[1 - \frac{\tau(1 + \beta\tau + \beta^2/3\tau^2)}{(1 + \beta + \beta^2/3)} \right]^2 \quad (\text{A2})$$

whereas, if we assume the quadratic law

$$R^* = 1 + \beta[1 - (1 - \tau)^2] \quad (\text{A3})$$

then similarly we obtain the result

$$H^* = \left[1 - \frac{\tau(1 + 2\beta\tau + (4\beta^2 - 2\beta)\tau^2/3 - \beta^2\tau^3 + \beta^2\tau^4/5)}{(1 + 4\beta/3 + 8\beta^2/15)} \right]^2 \quad (\text{A4})$$

L'EFFET DE L'EROSION DE TUYERE SUR LE TRANSFERT THERMIQUE DANS UNE POCHÉ D'ACIER FONDU DURANT LA COULEE

Résumé — La tuyère en réfractaire insérée dans l'isolation en brique, à la base d'une poche de coulée, s'érode lorsque l'acier fondu coule de la poche. On propose une théorie phénoménologique de l'érosion de la tuyère. Puis on étudie l'effet de celle-ci sur la température de l'écoulement. Les résultats sont comparés avec ceux du modèle théorique d'un orifice fixé et avec les observations.

DER EINFLUSS VON EROSION AUF DEN WÄRMEÜBERGANG AM AUSGUSS EINER GIESSPFANNE FÜR STAHL WÄHREND DES GIESSVORGANGS

Zusammenfassung — Der Schamotte-Ausguß am Boden einer Gießpfanne erodiert—wie man beobachtet—während der geschmolzene Stahl aus der Pfanne fließt. Es wird eine phänomenologische Theorie der Ausguß-Erosion aufgestellt. Dann wird der Einfluß der Ausguß-Erosion auf die Ausgußströmungstemperatur untersucht. Die Ergebnisse werden mit dem theoretischen Modell der festen Düse [1] und mit Betriebsbeobachtungen verglichen.

**ВЛИЯНИЕ ЭРОЗИИ ВЫПУСКНОГО ОТВЕРСТИЯ НА ТЕПЛОПЕРЕНОС В ЛИТЕЙНОМ
КОВШЕ ПРИ РАЗЛИВКЕ РАСПЛАВЛЕННОЙ СТАЛИ**

Аннотация — Выпускное отверстие из огнеупорной глины в кирпичной облицовке у основания литейного ковша разрушается при выпуске расплавленной стали. Предложена феноменологическая теория эрозии выпускного отверстия. Исследовано ее влияние на температурный режим при разливке. Проведено сравнение с теоретической моделью фиксированного отверстия и с данными заводских наблюдений.